



# ***HEATING BATH CIRCULATORS "VT" SERIES***

*Operating manual*

**!** *Before using this instrument, carefully read the operating manual.*

## TABLE OF CONTENTS

INTRODUCTION.....	3
Intended Use .....	3
Appearance and parts names .....	3
Environmental Conditions .....	3
Safety Recommendations.....	4
Using The VT Heating Bath Circulators .....	4
Preparation.....	4
GENERAL SPECIFICATIONS .....	6

This manual provides the information needed to operate heating bath circulators "VT3-1", "VT3-2", "VT4-1", "VT4-2", "VT5-1", "VT5-2", "VT7-1", "VT7-2", "VT8-1", "VT8-2", "VT10-1", "VT10-2", "VT14-1", "VT14-2", "VT18-1", "VT18-2", "VT20-1", "VT20-2", "VT25-1", "VT25-2".

## INTRODUCTION

### Intended Use

VT open heating bath circulators with stainless-steel bath tank are intended for internal and external temperature applications. They are mostly used for accurate temperature application to objects placed in the circulator bath. Temperature applications for external, closed systems are also possible via the attachable pump connectors.

### Appearance and parts names

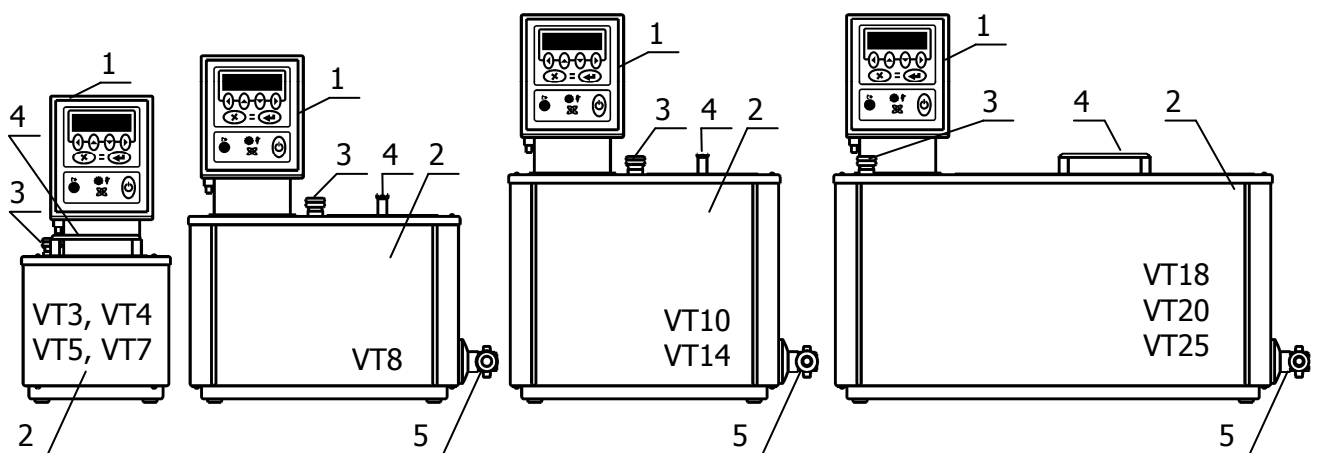

VT open heating bath circulators consist of (see figure above):

- 1 - heating immersion circulator M01;
- 2 - stainless-steel bath tank.

Each enclosure, aside from a bath tank, contains:

- 3 - adapter for test thermometer;
- 4 - bath cover;
- 5 - tank drain valve (except VT3, VT4, VT5 and VT7 models).

The operating principle of the bath circulators is based on supporting a preset constant temperature of flowing thermal fluid in the bath tank and in external system.

The circulation of the thermal fluid and maintaining of the preset temperature by means of heating is provided by immersion circulator 1.

The cooling of the thermal fluid is carried out by means of heat exchange with environment or cooling liquid, passed through internal coil of the immersion circulator.

### Environmental Conditions

Indoor use only.

Ambient temperature: +10...+35 °C.

Air humidity: max. relative humidity 80 % for temperatures up to +31 °C,

Max. mains fluctuation of  $\pm 10$  % are permissible.

## Safety Recommendations

Avoid strikes to the housing, vibrations, damage to the operating element panel (keypad, display), and contamination.

Do not store the instrument in aggressive atmosphere.

Protect the instrument from contamination.

Only qualified personnel are authorized to perform configuration, installation, maintenance and repairs of the circulator.

Routine operation can also be carried out by untrained personnel who should however be instructed by trained personnel.

**!** *CAUTION: The instrument is not for use in explosive atmosphere.*

## USING THE VT HEATING BATH CIRCULATORS

**!** *NOTE: Throughout this manual, keystrokes are represented in **bold type**; references to messages on the display are in "quotes."*

Before using bath circulator, carefully read the operating manual.

### Preparation

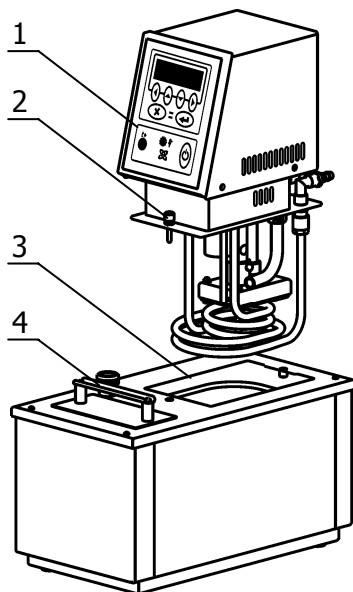

Carefully select a spot for installing instrument with free air access for circulator ventilation. Make sure it is far away from any kind of heat source.

Place the instrument on an even surface with a pad, made of nonflammable material.

Place the immersion circulator 1 in the port on the top of bath tank 3 (see figure on the left). Secure the circulator with screws 2.

**!** *While setting up circulator, supply cord should not be connected to the power source.*

Fill up the bath tank with thermal fluid through aperture under the bath cover 4. Level of thermal fluid should be 20-30 mm lower than the cover end.

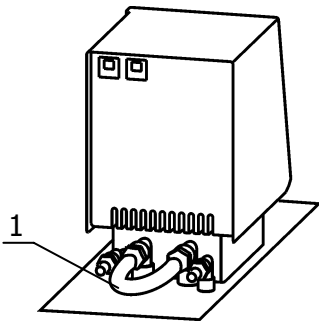

**!** *When filling bath up, do not spill any thermal fluid on the front panel of the circulator.*

To operate instrument without an external load, attach the pump connectors of the circulator by a hose. Secure the hose with clamps. Both come in the delivery package.

**!** *If using polymethylsiloxane as a thermal fluid, utilizing of silicone hose is prohibited.*

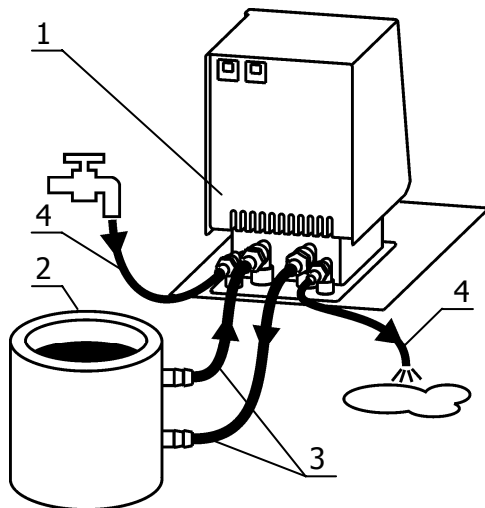

To operate circulator 1 with external load 2, attach hoses 3 to circulator connectors. Secure the hoses with the clamps.

To reduce the temperature difference between thermal fluid in bath and thermal fluid in external load, insulate the hoses.

To provide the necessary temperature mode for external load, select temperature setpoint of circulator by experiment or use an external temperature sensor.

When operating instrument with thermal fluid temperature close to ambient, it might be necessary to provide the cooling by means of internal coil. In order to do that, connect instrument to tap water supply with hoses 4, attached to the coil connectors. The flow of the cooling water must be even and slightly weak. The cooling is not necessary if thermal fluid temperature is at least 15 °C higher than ambient temperature.

To operate the instrument, read the "M01 Heating Immersion Circulator. Operating manual".

## GENERAL SPECIFICATIONS

Working temperature range:	
• VTx-1, VTxx-1	+20...+100 °C
• VTx-2, VTxx-2	+20...+200 °C
Temperature stability in the internal bath	±0.1 °C
Temperature uniformity in the internal bath	±0.1 °C
Power supply	230 V, 50/60 Hz
Bath volume	
• VT3-1, VT3-2	3 Liters
• VT4-1, VT4-2	4 Liters
• VT5-1, VT5-2	5 Liters
• VT7-1, VT7-2	7 Liters
• VT8-1, VT8-2	8 Liters
• VT10-1, VT10-2	10 Liters
• VT14-1, VT14-2	14 Liters
• VT18-1, VT18-2	18 Liters
• VT20-1, VT20-2	20 Liters
• VT25-1, VT25-2	25 Liters
Dimensions, W×D×H	
• VT3-1, VT3-2	170×285×380 mm
• VT4-1, VT4-2	185×345×380 mm
• VT5-1, VT5-2	170×285×430 mm
• VT7-1, VT7-2	185×345×430 mm
• VT8-1, VT8-2	380×275×430 mm
• VT10-1, VT10-2	285×315×455 mm
• VT14-1, VT14-2	380×275×430 mm
• VT18-1, VT18-2	585×335×480 mm
• VT20-1, VT20-2	455×315×435 mm
• VT25-1, VT25-2	585×335×480 mm
Bath opening	
• VT3-1, VT3-2, VT5-1, VT5-2	75×35 mm
• VT4-1, VT4-2, VT7-1, VT7-2	120×55 mm
• VT8-1, VT8-2, VT10-1, VT10-2	120×200 mm
• VT14-1, VT14-2	100×190 mm
• VT18-1, VT18-2, VT25-1, VT25-2	360×260 mm
• VT20-1, VT20-2	200×240 mm
Bath depth	
• VT3-1, VT3-2, VT4-1, VT4-2, VT8-1, VT8-2, VT18-1, VT18-2	150 mm
• VT5-1, VT5-2, VT7-1, VT7-2, VT10-1, VT10-2, VT25-1, VT25-2	200 mm
• VT14-1, VT14-2	230 mm
• VT20-1, VT20-2	210 mm
Weight	
• VT3-1, VT3-2, VT4-1, VT4-2, VT5-1, VT5-2	9 kg
• VT7-1, VT7-2, VT8-1, VT8-2	12 kg
• VT10-1, VT10-2, VT14-1, VT14-2	14 kg
• VT18-1, VT18-2, VT20-1, VT20-2, VT25-1, VT25-2	20 kg
Warranty	2 years